

Date 15/07/09

BULLETIN # 227

### CP124

#### TROUBLESHOOTING GUIDE FOR LOSS OF WELDING CURRENT

There are a number of different reasons why a CP124, Weldmatic 256 welder may not produce welding current and it can be difficult to pinpoint the exact reason. This bulletin is a guide to troubleshooting the problem.

Firstly the various reasons for loss of welding current are listed, and then a guide on how to check for each possibility is given. It is recommended that the easiest and most obvious possibilities are checked first, and that the more complicated tests are left until the easy solutions are eliminated.

It is assumed that there is **wire feed and gas flow**, but **no weld current** when the trigger is pressed.

The circuit diagrams for the 240 volt CP124 and W60 wirefeeder are given at the end of this bulletin. The basic guide can be used for the 480 volt version of the CP124 as well, but there will be some differences to the CP124 circuit diagram given here. Refer to the Owners Manual for the correct model if specific information is required.

Area	Test	Expected Result	Remedy
<b>MIG gun</b>	Try a different gun if possible. Remove the MIG gun handle covers and the strain relief at the wirefeeder end.	Check for poor connection/discoloration of the braided power cable.	Replace MIG gun
<b>Work lead and clamp</b>	Check for poor connection to the twistlock plug or the clamp.	Check for poor connection/discoloration	Remove any heat affected cable and reconnect.
<b>Weld cable</b>	Check for poor connection to the twistlock plug or the cable lug.	Check for poor connection/discoloration	Remove any heat affected cable and reconnect/replace plug or replace lug.
	Ensure that there is a good connection to the euro connector.	Check for poor connection/discoloration	Clean up/tighten connection
<b>Over temperature protection thermostats</b> Keep the power on with the fan running and allow the welding power source to	If still a problem, check the rectifier thermostat and welding transformer thermostat.	They should have zero resistance when cool. As a testing strategy only, a temporary short circuit can be placed across the thermostat.	Replace any thermostat which tests faulty. Part number CP104-16/2 for transformer thermostat (150° C). CP3-9/8 for rectifier thermostat (95° C).

#### QUALITY WELDING PRODUCTS, SYSTEMS AND SERVICES

The information provided in this sheet is accurate and reliable, however no warranty of accuracy or reliability is given and no responsibility arising in any other ways by errors or omissions is accepted. Any information involving mains or high voltage is intended for use by qualified electrical personnel only.

cool.			
<b>Wirefeed PCB PWA008</b>	a. measure volts dc between P10, Elec Cont +ve and P7, Elec Cont -ve (turns on the SCR Driver pcb output)	Should be approx +11 v dc when trigger is activated and approx. 0 v when no trigger.	If 11 v, PWA008 ok. If not, go to (b)
	b. If not present, check for 45 vdc between P10, Elec Cont +ve and P4, Wirefeed Motor -ve.	Should be approx. +45 v dc whenever power turned on.	If not present, PWA008 is faulty.
	c. If 45 v present at step (b), insert a jumper wire from P7, Elec Cont -ve to P4, Wirefeed Motor -ve	Welding transformer should power up with this jumper present.	If the transformer powers up with this jumper present, but doesn't when trigger pressed, PWA008 is faulty.
	Check resistance of Fine Voltage pot, RV8	Disconnect wires from P16 & P17. The resistance between P16 & P17 should vary from zero (min fine current) to 1 k ohm (max).	If resistance not correct, replace 1k pot or replace PWA008.
<b>Control cable and 6 pin plug/socket</b>	Check for good electrical connection at spade connectors in wirefeeder.	Crimp should be tight.	Replace any suspect spade connectors.
	Be suspicious of any evidence of previous repairs.	Use circuit diagram to ensure that the polarity of Elec Cont +ve and Elec Cont -ve signals are correct.	Repair faulty connection.
	Check control cable along its length.	Look for wire or insulation damage.	Repair/replace damaged cable or insulation.
	Check soldered connection to 6 pin plug and socket.	Look for cracked solder joints	Resolder any suspect joints
<b>SCR Module</b> Used as a phase controlling device to vary the amount of 240 v power supplied to the welding transformer, (adj. by fine voltage pot).	If the SCR is suspected of being faulty, a temporary connector can be used between terminals 1 and 2 on the SCR.	If the rest of the welding circuit is good, this will turn on the 240 volt input to the welding transformer and produce welding current.	The correct SCR is available from WIA as part number CP102-51/2N.
	The SCR can be tested with an SCR tester.	If the SCR tests faulty If the SCR tests good	Replace SCR Test the SCR Driver as below.
<b>Rectifier Circuit</b>	Check busbar connections	All connections should be clean and tight.	Clean and tighten connections
	Test the rectifier diodes	Expect to read approx. 0.46 v diode drop from each transformer secondary to both +ve and -ve output terminals	Rectifier may need to be disconnected and disassembled to locate specific problem areas.

<b>SCR Driver PCB, PWA001</b>	Measure volts ac between pins 7 & 8 on P1	Approx 30 volts ac	Check wiring from control transformer
	Measure volts dc between Pin 1 & 2 on P1	Approx 5 v dc fine volt pot min, 0 volt fine volt pot max.	Check control cable and 6 pin plug/socket as above
	If all the tests have been carried out and all items except SCR & SCR Driver PCB have been ruled out, it may still be difficult to definitively pinpoint the fault to the SCR Driver PCB or the SCR.	The output from the SCR driver pcb to the SCR gates is not able to be reliably measured with a digital multi meter.	Substitute a known good SCR or SCR Driver to determine the faulty part.

**CP124 (240 volt) Circuit Diagram**

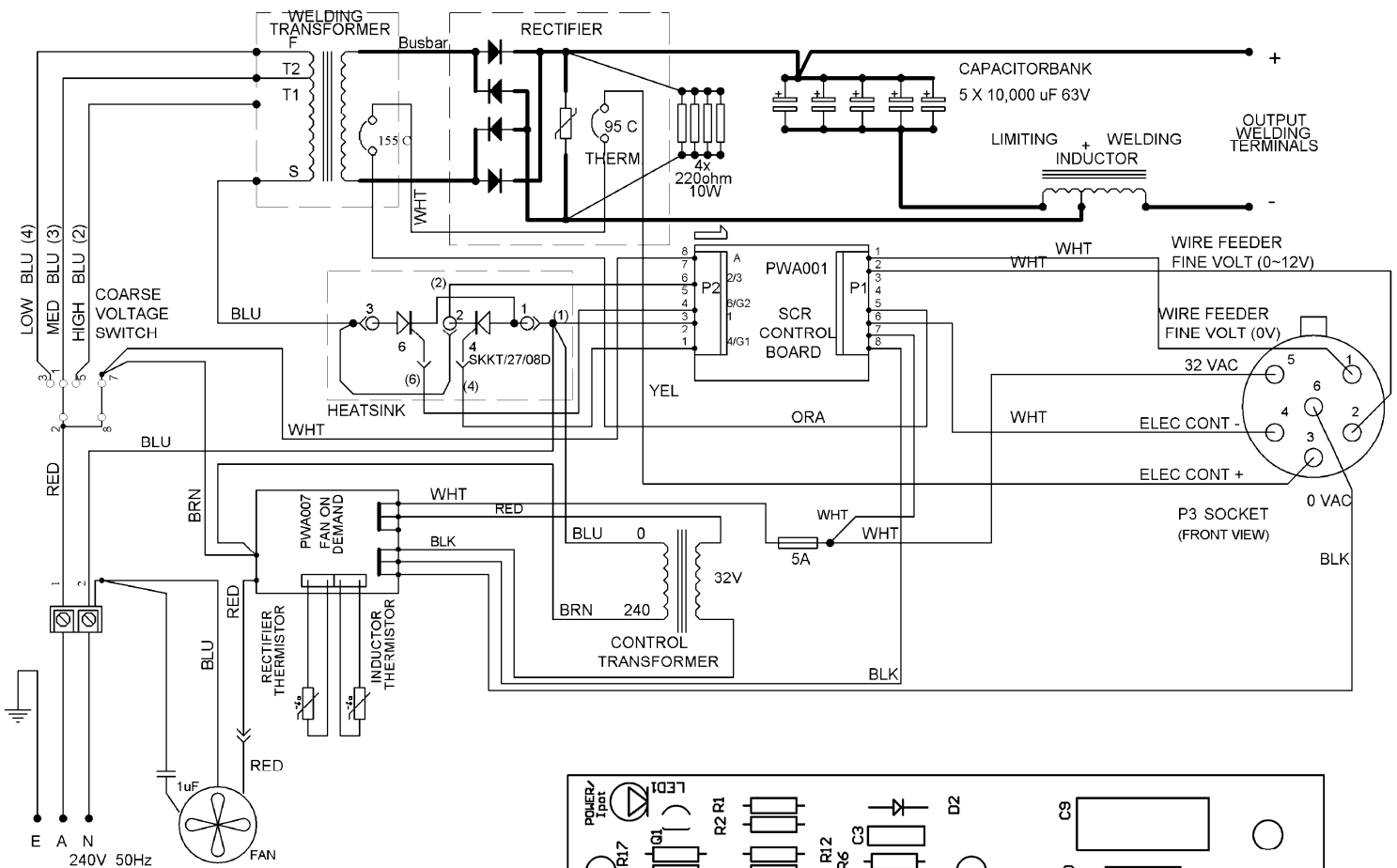

**SCR Control PCB, PWA001**

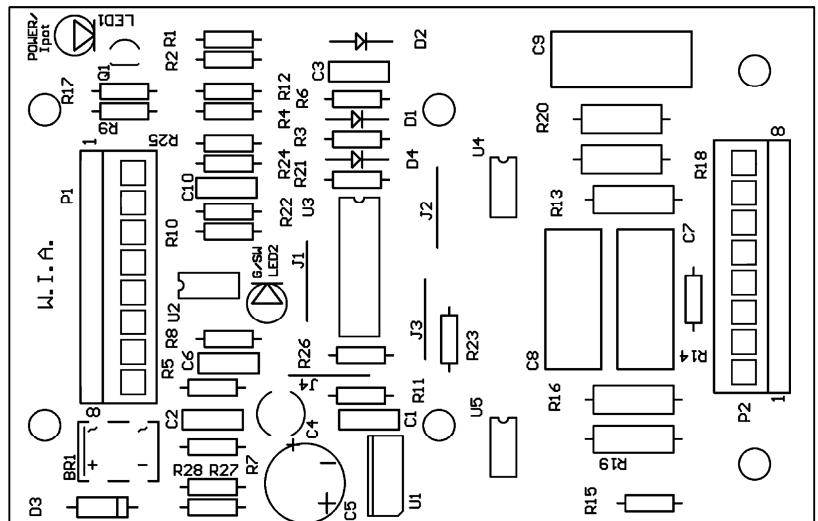

### W60 Circuit Diagram

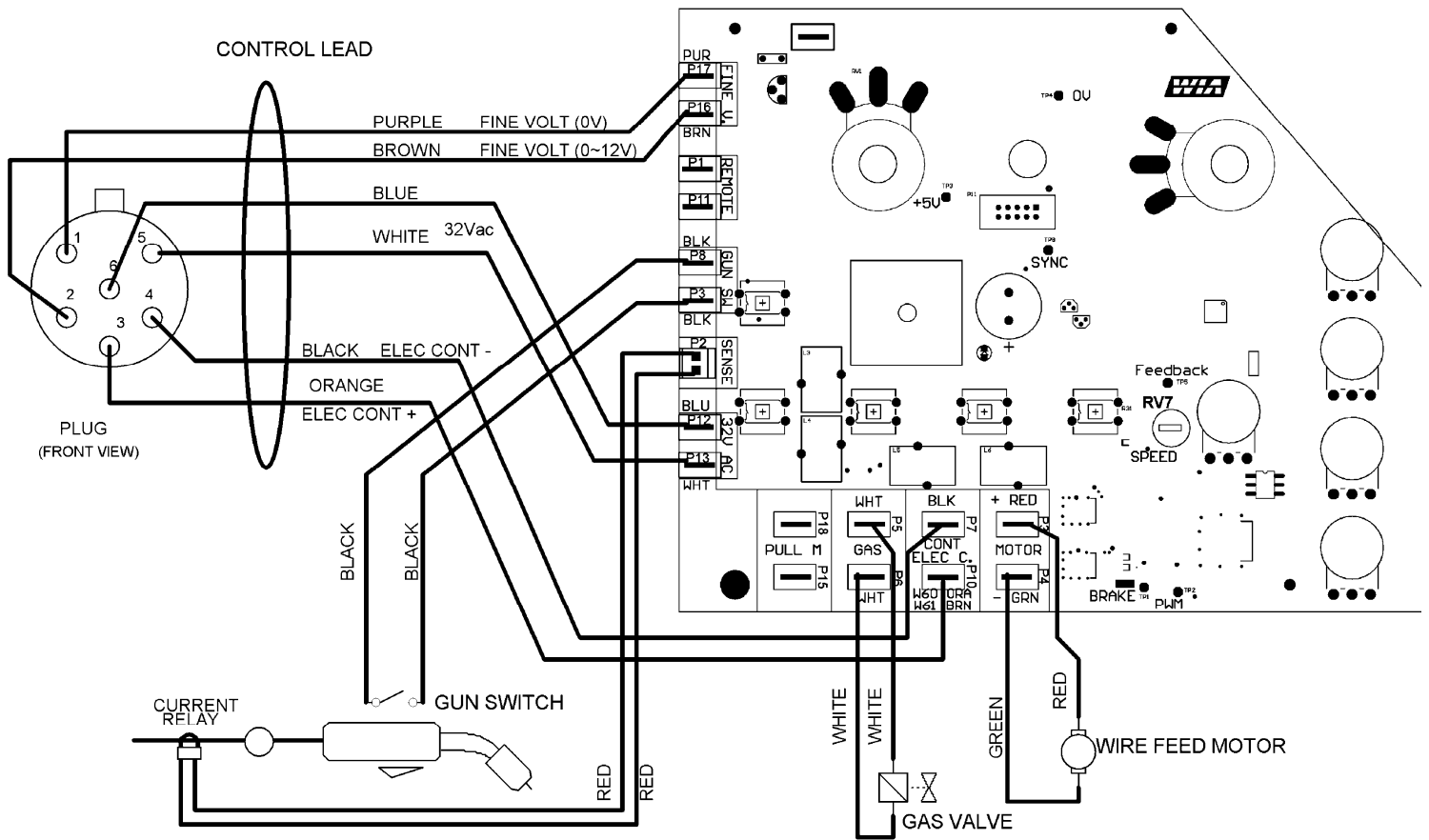

Hugh Stewart,  
Technical Service Coordinator