

GENERAL

BERNARD XT GUN REPAIRS

A number of parts used on the Bernard XT MIG guns (supplied with older model WIA machines) are not available from Bernard any more. The following information advises old numbers which are still current, and alternatives where the old numbers have been superseded.

If replacing BE1880135, (strain relief for XT gun), replace items 10, 11 & 12a together.

Item	Part No	Description
1	BE4392 BE4393	Nozzle, brass, tapered Nozzle, copper, tapered
2	BE7497 BE7488 BE7489 BE7496 BE7490 BE7498 BE7491	0.6mm contact tip 0.8mm contact tip 0.9mm contact tip 1.0mm contact tip 1.2mm contact tip 1.4mm contact tip 1.6mm contact tip
3	BE4335 BE4435	Gas Diffuser (Head) 300 amp Gas Diffuser (Head) 400 amp
4	BE4323	Cap
5	BEQT2-45 BEQT3-45	Body Tube Assembly (2" long) Body Tube Assembly (3" long)
6	BE4313B	End Fitting
7	BE4305	Cone Nut
8	BE1780006	Handle Kit (includes both halves, screws & posts)
9	BE5662	Trigger
10	BE2520033	Strain Relief
11	BE1880074	Rigid Strain Relief Kit (no cap, but includes both halves, screws, posts & spacers)
12	BE1199E	Euro Direct Plug Kit (includes)
12a	BE4822	Bushing
12b	BE4816	Euro Adaptor Nut
12c	BE4421	Large "O" ring at base of gas nipple
12d	BE9165	Small "O" ring on gas nipple
13	BE43115 BE43115X BE44215	Steel Liner 0.9 - 1.2mm Nylon Liner 0.9 - 1.2mm Steel Liner 1.6mm
14	BE1983 (300amp) BE1984 (400 amp) BE1790002	Rear Cone Nut Repair Kit (Includes: jacket clamp, conduit clamp, cone nut, end fitting, nipple, spacer, & butt connectors) Hang up hook kit (not illustrated)

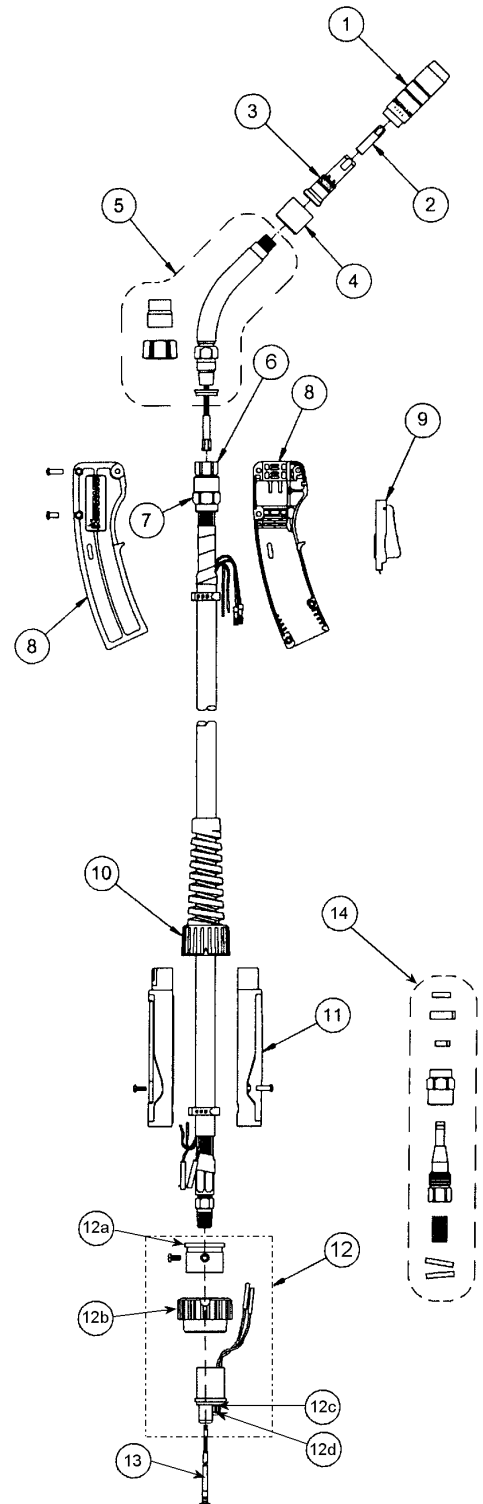

Hugh Stewart, Technical Service Coordinator

QUALITY WELDING PRODUCTS, SYSTEMS AND SERVICES

The information provided in this sheet is accurate and reliable, however no warranty of accuracy or reliability is given and no responsibility arising in any other ways by errors or omissions is accepted. Any information involving mains or high voltage is intended for use by qualified electrical personnel only.