

Date: 7 April 2003

BULLETIN # 178

CP34-43 SPARE PART

The W34-43 speed control pcb used on the CP34 is no longer available. However the W16-20 speed board can be converted into one using the following diagram as a guide.

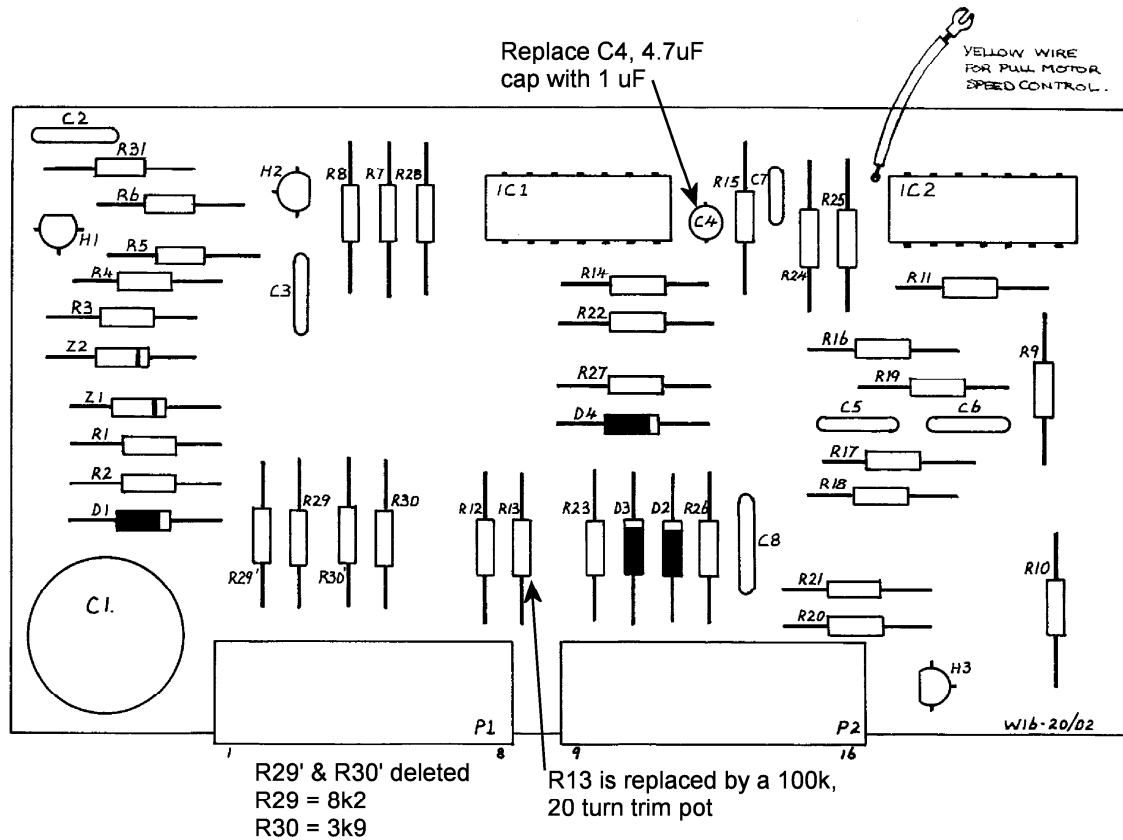

regards,
Hugh Stewart,
Technical Service Coordinator

QUALITY WELDING PRODUCTS, SYSTEMS AND SERVICES

The information provided in this sheet is accurate and reliable, however no warranty of accuracy or reliability is given and no responsibility arising in any other ways by errors or omissions is accepted. Any information involving mains or high voltage is intended for use by qualified electrical personnel only.