

**WELDING INDUSTRIES OF AUSTRALIA**  
A DIVISION OF WELDING INDUSTRIES LTD  
ABN 18 004 547 111

**Telephone 1300 300 884 Facsimile 1300 301 884**

Email: [Info@welding.com.au](mailto:Info@welding.com.au)

**[www.welding.com.au](http://www.welding.com.au)**

**OWNERS MANUAL**

**INDURO VRD10**

**MODEL MC102-0**

**01/2003**

The information contained in this manual is set out to enable you to properly maintain your new equipment and ensure that you obtain maximum operating efficiency.

Please ensure that this information is kept in a safe place for ready reference when required at any future time.

When requesting spare parts, please quote the model and serial number of the machine and part number of the item required. All relevant numbers are shown in lists contained in this manual. Failure to supply this information may result in unnecessary delays in supplying the correct parts.

## SAFETY

Before this equipment is put into operation, the SAFE PRACTICES section at the back of the manual must be read completely. This will help to avoid possible injury due to misuse or improper welding applications.

## CONTENTS

Section	Page
1 .....	Introduction ..... 3
2 .....	Receiving ..... 4
3 .....	Specifications ..... 4
4 .....	Power Source Controls ..... 5
5 .....	Operation ..... 6
6 .....	Connection to Electrical Mains Power Supply ... 6
7 .....	MMAW Welding ..... 7
8 .....	GTAW Welding ..... 9
9 .....	General Maintenance ..... 11
10 .....	Fault Finding, No Welding Current ..... 11
11 .....	Service Information ..... 11
12 .....	Parts List ..... 13
13 .....	Safe Practices ..... 15

## FIGURES

Figure	Page
1 .....	Power Source Controls ..... 5
2 .....	Connections for MMAW ..... 7
3 .....	Striking the Arc ..... 8
4 .....	Cable and Hose Connections for GTAW ..... 9
5 .....	Induro VRD <sup>10</sup> Circuit Diagram ..... 12
6 .....	Induro VRD <sup>10</sup> Parts Diagram ..... 14

## 1. INTRODUCTION

### MMAW

Manual Metal Arc Welding is a process where an arc is struck between a flux-coated consumables electrode and the work piece. The arc and the weld pool are both shielded by gases generated by the flux coating of the electrode.

The INDURO VRD<sup>10</sup> has been designed to be used with 2.0mm, 2.5mm and 3.2mm diameter electrodes. The smaller are used when welding at lower currents, such as sheet metal applications. Increasing the electrode diameter permits higher welding currents to be selected.

WIA manufactures a wide range of mild steel and special purpose electrodes which cater for home workshop, rural, and industrial requirements. Some popular AUSTARC electrodes are listed below. The correctly selected AUSTARC electrode used in conjunction with your new INDURO VRD<sup>10</sup> will influence the quality of the weld, and the stability of the arc.

#### **Austarc 12P, Classification E4112.**

A popular general purpose electrode used with ease in all positions, vertical up or down. The smooth forceful arc makes it an ideal electrode for all general mild steel applications.

#### **Austarc 13S, Classification E4113.**

A smooth running electrode with a soft arc, particularly suited to light sheetmetal and smooth mitre fillet welds.

#### **Austarc 16TC, Classification E4816.**

A low hydrogen electrode with good arc stability and out-of-position welding characteristics. This electrode is ideal for medium carbon steels, or steels of unknown analysis.

#### **Unicord**

A high tensile (50tsi), chromium nickel electrode specially formulated for joining all alloy steels and irons, and for tool and die maintenance.

### GTAW

Gas Tungsten Arc Welding is a welding process where the arc is struck between a non-consumable tungsten electrode and the work piece. A ceramic nozzle surrounds the tungsten electrode and directs a flow of inert gas, usually Argon, over the electrode and the weld zone. If filler metal is required, it is hand fed into the welding arc. The DC current of the INDURO VRD<sup>10</sup> is suitable for welding most ferrous and non-ferrous metals, but is not suitable for welding Aluminium for which an AC machine is required.

## 2. RECEIVING

Check the equipment received against the shipping invoice to make sure the shipment is complete and undamaged. If any damage has occurred in transit, please immediately notify your supplier.

The INDURO VRD<sup>10</sup> package contains:

- Induro VRD<sup>10</sup> Inverter Power Source
- (This) Owners Manual

### Optional additional items for Induro VRD<sup>10</sup>:

Arc Lead Kit - 3m ..... AA58-0/3

Includes:

- 3 metre welding lead with electrode holder
- 3 metre work lead with clamp

TIG + Arc Lead Kit ..... AA59-0/3

Includes:

- 3 metre welding lead with electrode holder
- 3 metre work lead with clamp
- 3m TIG torch with starter kit & adaptor
- argon flow gauge regulator

## 3. SPECIFICATIONS

Primary Voltage..... 240 Volts AC, +/- 10%, 50/60 Hz  
 Maximum Primary Demand ..... 24.5 Amps  
 Rated Input Current ..... 10 Amps  
 Welding Current Range ..... 5 - 125 Amps  
 Duty Cycle..... 125 Amps @ 25.0v, 20% Duty Cycle  
 Open Circuit Voltage..... when welding - 57 Volts DC  
 .....with VRD operated – 11.2v dc  
 Mass.....4.8 Kg

This power source is supplied fitted with a 10 amp plug and is intended for use from a 10 amp GPO.

### IMPORTANT NOTICE

WARRANTY MAY BE VOIDED IF EQUIPMENT IS POWERED FROM AN UNSUITABLE ENGINE DRIVEN GENERATOR.

Any generator used to power this equipment must have a minimum capacity of 6,000 watts continuous and must incorporate output voltage regulation.

Generators without voltage regulation must have a capacity of at least 16,000 watts.

## 4. POWER SOURCE CONTROLS

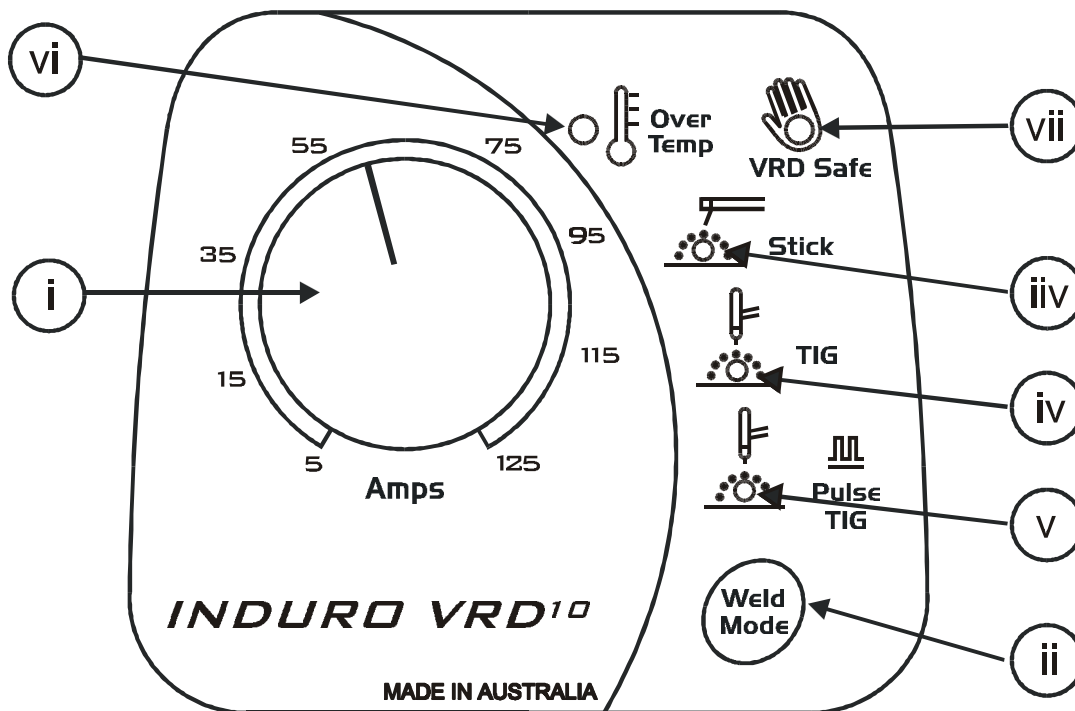

FIGURE 1. POWER SOURCE CONTROLS

### i. CURRENT CONTROL

This control sets the output current level of the power source within the range 5 - 125 Amps. Rotate the knob clockwise to increase the output current.

### ii. WELD MODE

Press this button to step between *Stick* Mode, *TIG* Mode & *Pulse TIG* Mode

### iii. STICK MODE

This LED is illuminated when *Stick* Mode (Manual Metal Arc Welding) is selected.

### iv. TIG MODE

This LED is illuminated when *TIG* Mode (Gas Tungsten Arc Welding) is selected.

### v. PULSE TIG MODE

This LED is illuminated when *Pulse TIG* (Pulse Gas Tungsten Arc Welding) Mode is selected.

### vi. OVER TEMPERATURE INDICATOR

This LED is illuminated if any internal thermal protection devices have operated.

### vii. VRD SAFE MODE INDICATOR

This LED is illuminated to indicate that the voltage across the output terminals is at a safe level.

### POWER ON/OFF SWITCH (located on the rear panel)

In the OFF position, this switch isolates the power source from the mains power supply. The fan will continue to rotate for approximately 5 seconds after the unit is turned off until the stored energy in the unit's power supply is consumed.

## 5. OPERATION

### VRD (VOLTAGE REDUCING DEVICE) OPERATION

The Induro VRD<sup>10</sup> incorporates an integral Voltage Reduction Device. This device is designed to improve operator safety by reducing the voltage across the welding leads to a safe level whenever the machine is not welding.

The machine output drops to the safe voltage **0.2** seconds after welding stops. The output switches back to the welding voltage when the resistance from electrode to workpiece falls below 200 ohms.

The Green VRD Safe LED when continuously lit indicates that the voltage across the output terminals is at a safe level.

### SLEEP MODE

The Induro VRD<sup>10</sup> goes into “sleep mode” when not used for more than 10 minutes. This is a low power consumption mode which includes shutting down the fan. As soon as the operator attempts to strike an arc or if any button is pressed, the Induro VRD<sup>10</sup> automatically “wakes up” in the mode in which it was last used.

Sleep mode is indicated by the currently selected weld mode LED blinking slowly, with all other LEDs being off.

## 6. CONNECTION TO ELECTRICAL MAINS POWER SUPPLY

The INDURO VRD<sup>10</sup> is supplied with a 15 Amp Heavy Duty mains power supply cable fitted with a 10 Amp plug. This cable may be connected to a correctly installed 10 Amp GPO (General Purpose Outlet). The recommended Supply Circuit Breaker rating is 20 Amps.

If the supply cord is damaged, it must be replaced by the manufacturer or its service agent or a similarly qualified person in order to avoid a hazard. The replacement cable is available from WIA Sales and Service agents, part no. MC102-30.

If an extension power supply cable is to be used, it should be rated for a minimum of 15 Amps to avoid excessive voltage drop, especially over long lengths. If the mains voltage at the machine falls below 200 volts, the machine will stop welding and the “Over Temperature” light will flash. To reset, turn the machine OFF, then back ON again.

As noted previously, it is not recommended that the INDURO VRD<sup>10</sup> be powered from small engine-driven generator sets unless they have adequate voltage regulation due to the peaks of supply voltage which can occur with some equipment of this type. Excessive voltage peaks can damage the circuits of the welder.

## 7. MMAW WELDING

### A. CONNECTION FOR MMAW WELDING

It is important to select the electrode polarity in accordance with the manufacturers recommendations for that electrode. Most common electrodes are operated with the electrode at positive polarity, as illustrated in Figure 2.

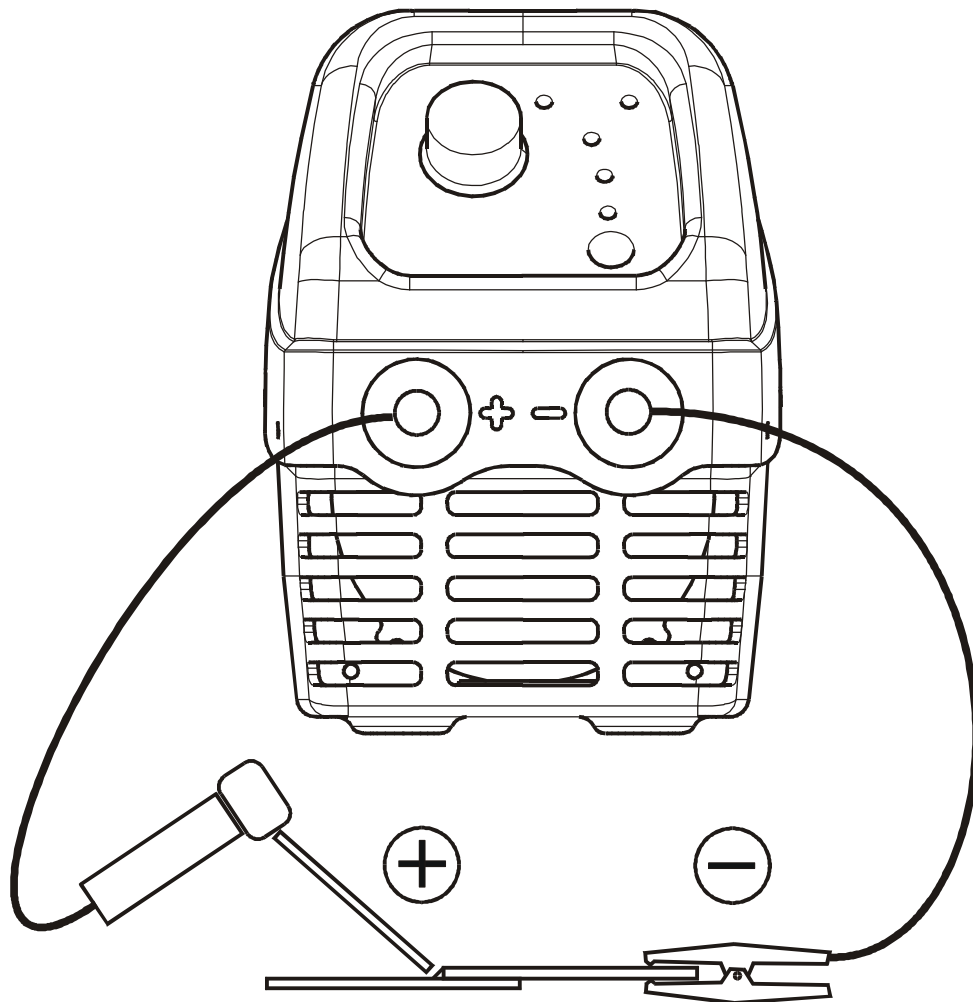

FIGURE 2. CONNECTIONS FOR MMAW, ELECTRODE POSITIVE

## B. MMAW OPERATION

Be certain that you are wearing suitable protective clothing, gloves etc. and that you are working in a non-hazardous area. If necessary, refer again to the SAFE PRACTICES section of this manual.

With a grinder or file, remove surface scale from a small area of the workpiece and connect the Work Clamp to that position.

Select an appropriate welding current for the electrode diameter by setting the knob on the machine front panel. Turn on the power switch located on the rear panel. Wait approx 5 seconds as the unit goes through its initiation sequence. Press the Weld Mode button until the Stick Mode LED is lit. The Induro VRD<sup>10</sup> keeps the last mode used in memory, so this step is only necessary when using a different mode to that used last.

For maximum operator safety, and as required in many industrial and mining situations, the Induro VRD<sup>10</sup> is permanently connected for full VRD operation. This means that the open circuit voltage is reduced to a low level (11 volts) whenever the machine is not arcing. As required by Australian Standard AS3195, the machine goes to normal arcing mode whenever the electrical resistance between electrode and workpiece falls below 200 ohms. This requires good contact between the electrode and workpiece.

Arc initiation with a VRD type machine is best achieved using a new, but easy to learn technique. Firstly, check that the electrode core wire is exposed at the arcing end of the electrode, then place it in the electrode holder. Gently rest the electrode end on the workpiece, then rotate the electrode approximately a ¼ turn. As the arc initiates, lift the electrode slightly away, aiming to establish an arc length of approximately 3mm.

As a general rule, the arc should be held as short as possible while still giving stable burn off and good weld appearance. An arc which is too long causes an unwieldy flow of metal with a rough weld appearance and reduced penetration. An arc too short leads to a narrow weld deposit and “stuttery” arc characteristics, and the electrode is liable to freeze onto the work piece.

Always fill the crater which tends to form at the end of a weld deposit, by pausing momentarily before withdrawing the electrode to break the arc. Unfilled craters are a point of weakness, and can lead to weld cracking.

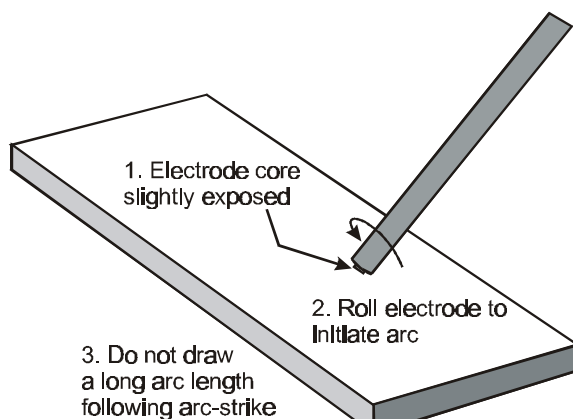

**FIGURE 3. STRIKING THE ARC**



## 8. GTAW WELDING

### A. CONNECTION FOR GTAW WELDING

For GTAW, the torch is connected electrode negative. Figure 3 illustrates the correct connection of the welding torch and gas supply. Welding grade Argon is the shielding gas most commonly used for DC GTAW welding.

Before initial use of the welding torch, allow gas to purge the torch and hoses for 5 minutes at approximately 10 litres/min. For welding purposes, the gas flow rate should be set in the range 2 - 5 litres/min.

Tungsten electrodes for DC GTAW should be 1 - 2% Thoriated or Witstar. This type will provide the best arc initiation, arc stability and tip shape retention characteristics. Thoriated electrodes can be recognised by a red coded end. The tungsten electrode is ground to a point, with the grinding marks pointing towards the tip. For welding currents less than 20 amps, the included angle of the point should be 30°, for currents greater than 20 amps, the recommended angle is 60°. When set in the torch, the tungsten should protrude 6mm from the ceramic gas nozzle.

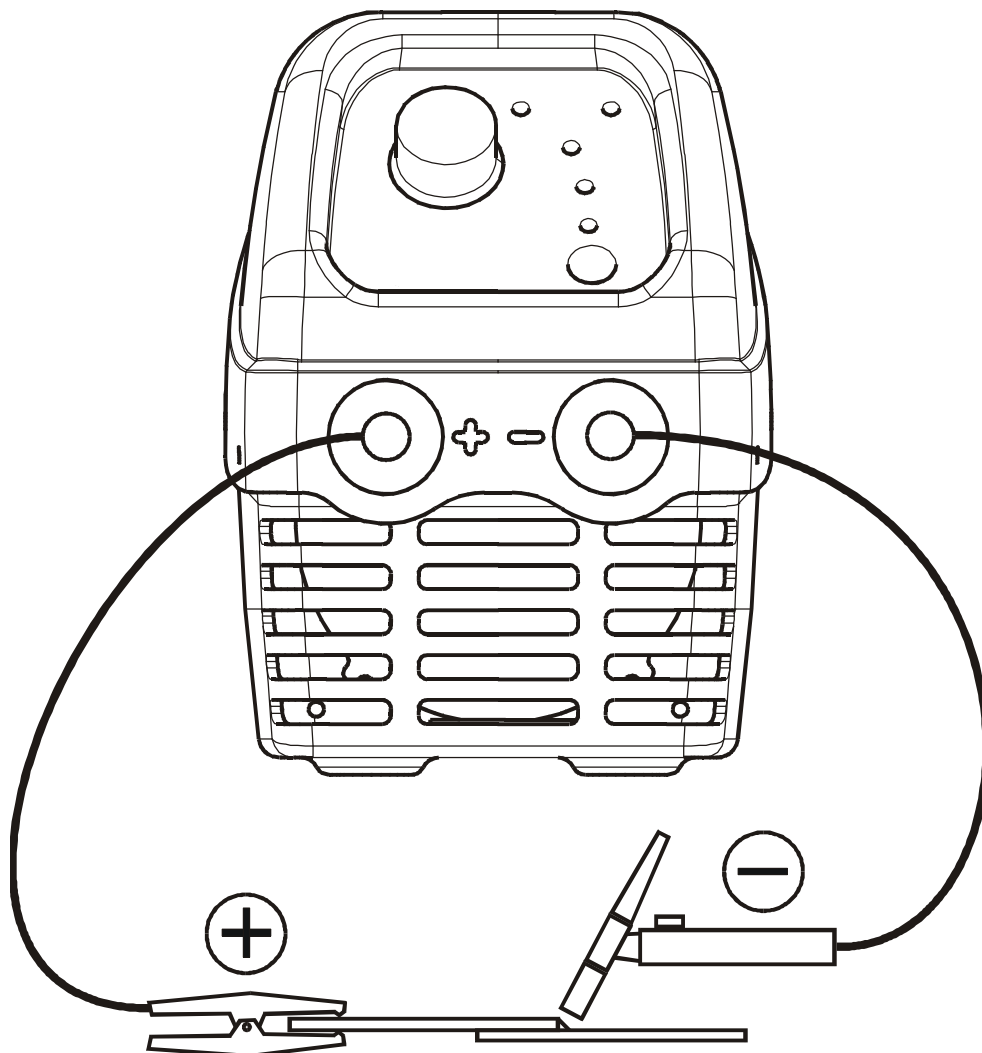

FIGURE 4. CABLE AND HOSE CONNECTIONS FOR GTAW

## **B. GTAW OPERATION**

Connect the Work Clamp to the work piece.

Turn on the power switch located on the rear panel. Wait approx 5 seconds as the unit goes through its initiation sequence.

Press the Weld Mode button until the TIG Mode LED is lit. The Induro VRD<sup>10</sup> keeps the last mode used in memory, so this step is only necessary when using a different mode to that used last.

Select an appropriate welding current for the job by setting the knob on the machine front panel.

To initiate the arc, the tungsten electrode should be touched onto the work piece, then lifted in a smooth movement to establish an arc length slightly larger than the diameter of the electrode. When the arc is stable, it can be transferred to the work piece.

Use of a copper striking plate can be used to avoid electrode contamination. The electrode can also be contaminated by contact with the filler rod. A contaminated electrode produces an unstable arc.

## **C. PULSE GTAW OPERATION**

Use Pulse TIG mode when TIG welding thin materials. The welding current is generated in a series of pulses at a preset frequency and duration. This pulsing action controls the heat input to the material, while still providing a high enough current to achieve weld penetration.

To select Pulse TIG Mode, press the Weld Mode button until the Pulse TIG Mode LED is lit. The Induro VRD<sup>10</sup> keeps the last mode used in memory, so this step is only necessary when using a different mode to that used last.

Select an appropriate welding current for the job by setting the knob on the machine front panel.

Initiate the arc in the same manner as that described above.

## 9. GENERAL MAINTENANCE

*Before removing the machine cover, ENSURE that the unit is disconnected from the mains power supply. When the unit is energised LETHAL VOLTAGES are present on the electrical components enclosed.*

The Induro VRD<sup>10</sup> turns the cooling fan off when it is not required to reduce dust intake. However care should be taken to prevent excessive dust and dirt entering the welding power source by positioning the unit away from any grinding operations.

## 10. FAULT FINDING, NO WELDING CURRENT

### Check:

1. That mains supply is available at the INDURO VRD<sup>10</sup> power source. At least one of the key pad LED's should be lit. If not, test that the power point works by plugging in another appliance.
2. That the welding and work leads are connected securely to the output sockets at the front of the machine.
3. For continuity of the work lead, work clamp and electrode holder. Loose connections can prevent proper flow of the welding current.
4. The INDURO VRD<sup>10</sup> welding power source incorporates an in built protection device which will trip if the unit is overloaded. In this event, the machine will not deliver welding current, and the red Over Temp LED will be illuminated. If the thermal overload protection device has been tripped, leave the machine energised with the fan running to achieve the maximum cooling rate.
5. If the mains voltage at the machine falls below 200 volts, the machine will stop welding and the Over Temp light will flash. To reset, turn the machine OFF, then back ON again. Check for and remedy the cause of excessive primary voltage drop. A typical cause may be an undersize or excessively long extension lead.

If equipment failure is suspected, forward the unit to your nearest authorised WIA qualified service agent. To find out your nearest qualified service agent call 1300 300 884.

## 11. SERVICE INFORMATION

*NOTE that the following information is intended for use by Qualified Service Personnel. When the unit is energised LETHAL VOLTAGES are present on the electrical and electronic components. It is not intended that persons without suitable training and knowledge attempt to perform service tasks on the components of this welder.*

The electrical components of the equipment are shown in the circuit diagram below. The INDURO VRD<sup>10</sup> is an inverter type design, where the mains supply is first rectified, filtered, then chopped to a high frequency before being applied to the welding transformer. The output of this transformer is rectified to form the welding output of the machine.

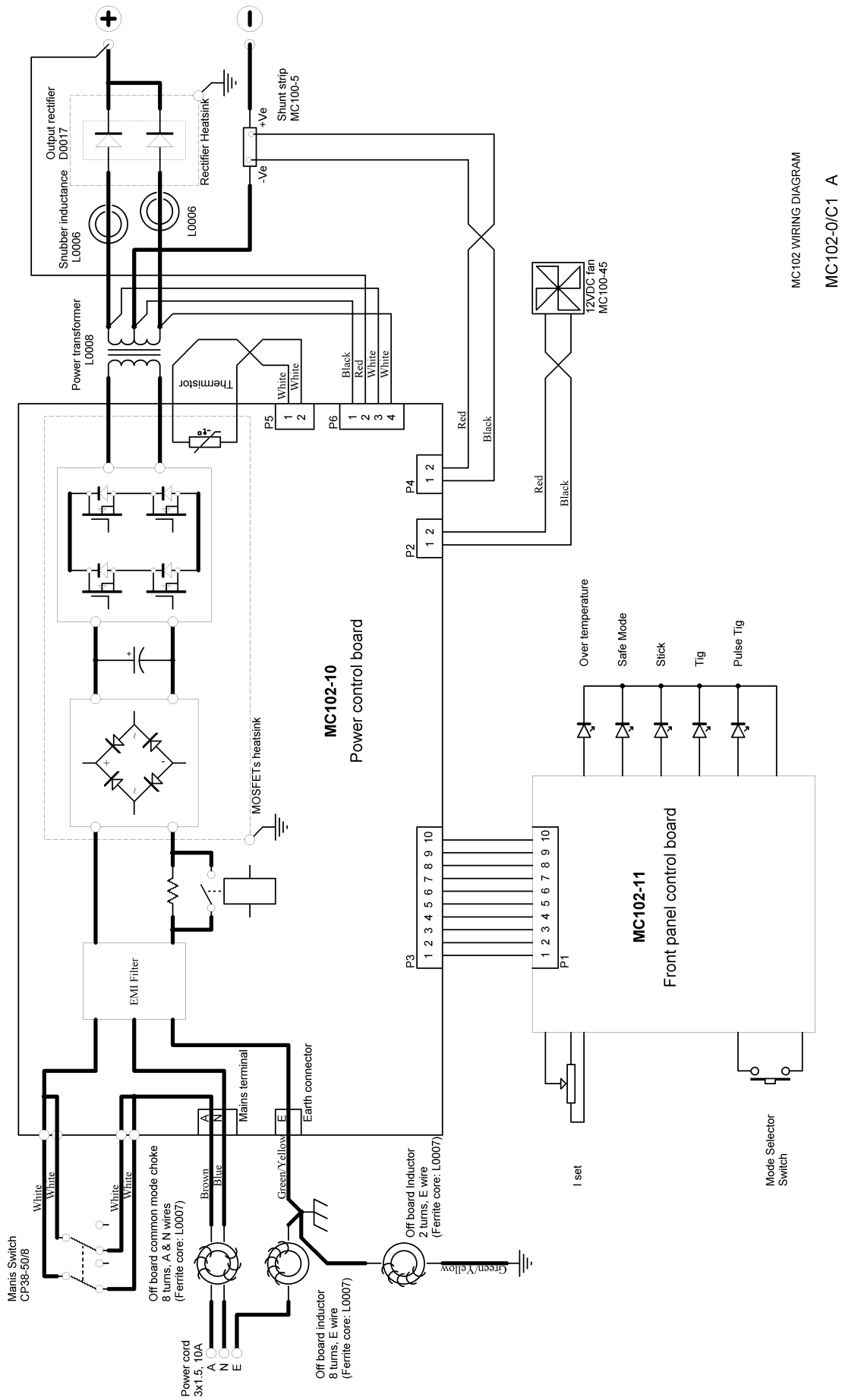

MC102 WIRING DIAGRAM  
MC102-0/C1 A

FIGURE 5. INDURO VRD10 CIRCUIT DIAGRAM

**12. PARTS LIST**

<b>Item #</b>	<b>Qty</b>	<b>Part #</b>	<b>Description</b>
1	1	MC100-48	Upper Case
2	1	MC102-55	Sticker Set for Upper Case (not illustrated, contains all labels and decal)
3	1	MC100-47	Lower Case
4	1	MC100-45	Cooling Fan Assembly
5	1	CP101-0/17	Fan Grille
6	1	MC100-53	Shoulder Strap
7	1	CP38-50/8	On/Off Switch
8	1	MC100-37	On/Off Switch Sealing Boot
9	2	SA140-0/2	Output Socket, 25mm Dinsel
10	1	MC102-30	15A Primary Supply Cable & 10 A Plug
11	1	M0004	Primary Cable Grip
12	1	M0005	Primary Cable Nut
13	1	MC102-10N	Power Control PCB
includes	1	E0010	Relay
14	1	MC102-11N	Front Panel Control PCB
includes	1	CP34-36/2	Current Adjustment Potentiometer
15	1	MC100-54	Current Adjustment Knob
16	1	MC100-43	Thermistor Assembly
17	1	D0018	Input Rectifier, 50A, 240V
18	4	D0019	MOSFET
19	1	L0008	Planar Transformer
20	1	D0017	Dual Output Rectifier Module
21	2	L0006	Toroid, Amorphous Metal
22	1	MC100-5	Shunt resistor Assembly
23	6	NSS316WP	Speed Nut

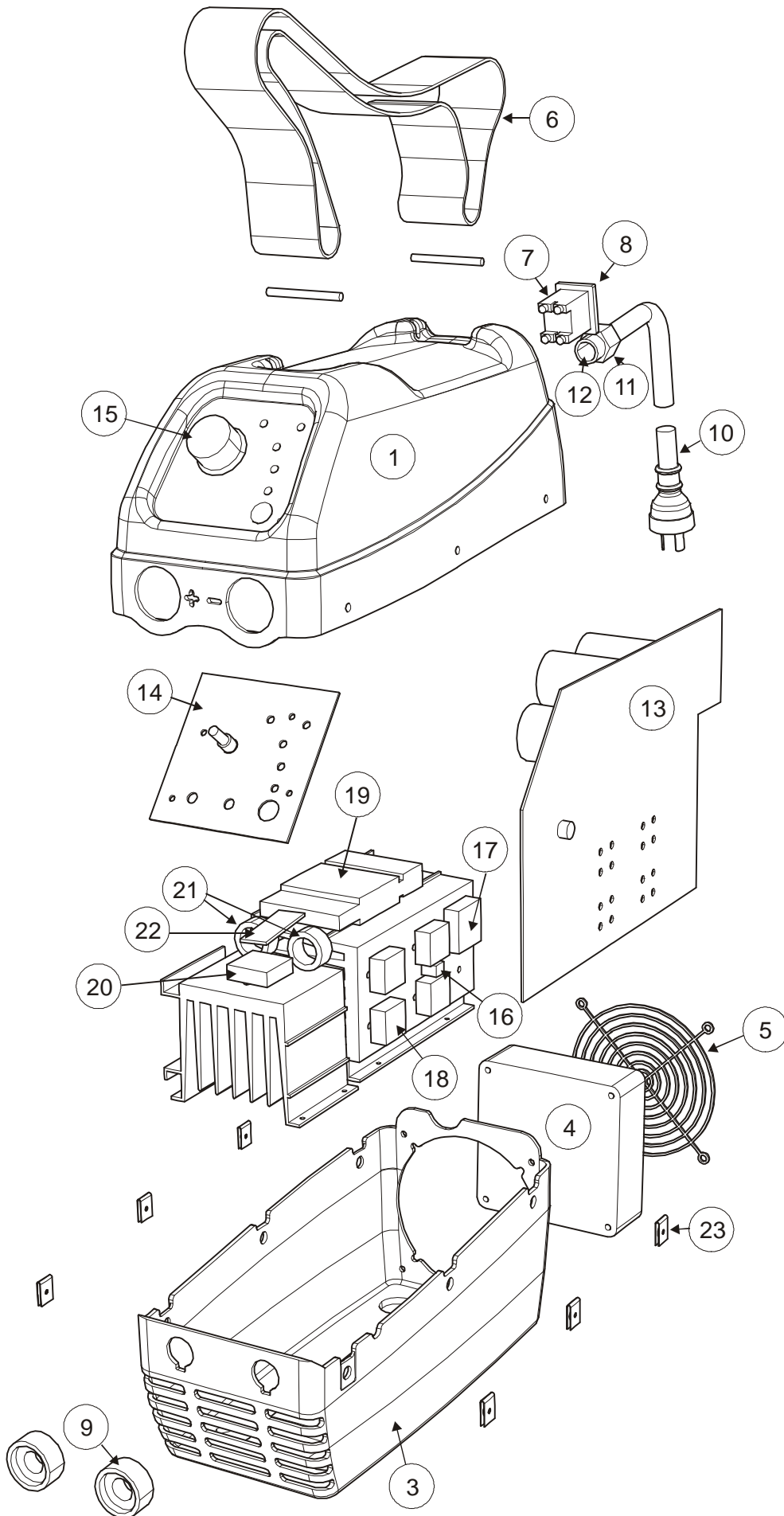

FIGURE 6. INDURO VRD<sup>10</sup> PARTS DIAGRAM

### 13. SAFE PRACTICES

These notes are provided in the interests of improving operator safety. They should be considered only as a basic guide to Safe Working Habits. A full list of Standards pertaining to industry is available from the Standards Association of Australia, also various State Electricity Authorities, Departments of Labour and Industry or Mines Department and other Local Health or Safety Inspection Authorities may have additional requirements. WTIA Technical Note TN7-98 also provides a comprehensive guide to safe practices in welding.

#### EYE PROTECTION

NEVER LOOK AT AN ARC WITHOUT PROTECTION. Wear a full face helmet, with an appropriate shade filter lens protected by clear cover glass. This is a MUST for any arc process to protect the eyes from radiant energy and flying sparks etc.. Replace the cover glass when it is broken, pitted, or spattered.

#### Recommended shade filter lens.

Amps	TIG	MMAW	MIG	Pulsed MIG
0-100 .....	10.....	9.....	10.....	12-13
100-150 .....	11.....	10.....	10.....	12-13
150-200 .....	12.....	10-11.....	11-12.....	12-13
200-300 .....	13.....	11.....	12-13.....	12-13
300-400 .....	14.....	12.....	13.....	14
400-500 .....	-- .....	13.....	14.....	14
500 + .....	-- .....	-- .....	14.....	14

#### BURN PROTECTION.

The welding arc is intense and visibly bright. Its radiation can damage eyes, penetrate lightweight clothing, reflect from light-coloured surfaces, and burn the skin and eyes. Burns resulting from gas-shielded arcs resemble acute sunburn, but can be more severe and painful.

Wear protective clothing - leather or heat resistant gloves, hat, and safety-toe boots. Button shirt collar and pocket flaps, and wear cuffless trousers to avoid entry of sparks and slag.

Avoid oily or greasy clothing. A spark may ignite them. Hot metal such as electrode stubs and work pieces should never be handled without gloves.

Ear plugs should be worn when welding in overhead positions or in a confined space. A hard hat should be worn when others are working overhead.

Flammable hair preparations should not be used by persons intending to weld or cut.

**TOXIC FUME PREVENTION.**

Adequate ventilation with air is essential. Severe discomfort, illness or death can result from fumes, vapours, heat, or oxygen depletion that welding or cutting may produce. NEVER ventilate with oxygen.

Lead, cadmium, zinc, mercury, and beryllium bearing and similar materials when welded or cut may produce harmful concentrations of toxic fumes. Adequate local exhaust ventilation must be used, or each person in the area as well as the operator must wear an air-supplied respirator. For beryllium, both must be used.

Metals coated with or containing materials that emit fumes should not be heated unless coating is removed from the work surface, the area is well ventilated, or the operator wears an air-supplied respirator.

Work in a confined space only while it is being ventilated and, if necessary, while wearing air-supplied respirator.

Vapours from chlorinated solvents can be decomposed by the heat of the arc (or flame) to form PHOSGENE, a highly toxic gas, and lung and eye irritating products. The ultra-violet (radiant) energy of the arc can also decompose trichlorethylene and perchlorethylene vapours to form phosgene. Do not weld or cut where solvent vapours can be drawn into the welding or cutting atmosphere or where the radiant energy can penetrate to atmospheres containing even minute amounts of trichlorethylene or perchlorethylene.

**FIRE AND EXPLOSION PREVENTION.**

Be aware that flying sparks or falling slag can pass through cracks, along pipes, through windows or doors, and through wall or floor openings, out of sight of the operator. Sparks and slag can travel up to 10 metres from the arc.

Keep equipment clean and operable, free of oil, grease, and (in electrical parts) of metallic particles that can cause short circuits.

If combustibles are present in the work area, do NOT weld or cut. Move the work if practicable, to an area free of combustibles. Avoid paint spray rooms, dip tanks, storage areas, ventilators. If the work can not be moved, move combustibles at least 10 metres away out of reach of sparks and heat; or protect against ignition with suitable and snug-fitting fire-resistant covers or shields.

Walls touching combustibles on opposite sides should not be welded on or cut. Walls, ceilings, and floor near work should be protected by heat-resistant covers or shields.



A person acting as Fire Watcher must be standing by with suitable fire extinguishing equipment during and for some time after welding or cutting if;

- Combustibles (including building construction) are within 10 metres.
- Combustibles are further than 10 metres but can be ignited by sparks.
- Openings (concealed or visible) in floors or walls within 10 metres may expose combustibles to sparks.
- Combustibles adjacent to walls, ceilings, roofs, or metal partitions can be ignited by radiant or conducted heat.

After work is done, check that area is free of sparks, glowing embers, and flames.

Any tank or drum which has contained combustibles can produce flammable vapours when heated. Such a container must never be welded on or cut, unless it has first been cleaned as described in AS.1674-1974, the S.A.A. Cutting and Welding Safety Code. This includes a thorough steam or caustic cleaning (or a solvent or water washing, depending on the combustible's solubility), followed by purging and inerting with nitrogen or carbon dioxide, and using protective equipment as recommended in AS.1674-1974. Water-filling just below working level may substitute for inerting.

Hollow castings or containers must be vented before welding or cutting. They can explode. Never weld or cut where the air may contain flammable dust, gas, or liquid vapours.

## **SHOCK PREVENTION.**

Exposed conductors or other bare metal in the welding circuit, or ungrounded electrically alive equipment can fatally shock a person whose body becomes a conductor. Ensure that the machine is correctly connected and earthed. If unsure have machine installed by a qualified electrician. On mobile or portable equipment, regularly inspect condition of trailing power leads and connecting plugs. Repair or replace damaged leads.

Fully insulated electrode holders should be used. Do not use holders with protruding screws. Fully insulated lock-type connectors should be used to join welding cable lengths.

Terminals and other exposed parts of electrical units should have insulated knobs or covers secured before operation.